

© DEN HARTOG INDUSTRIES, INC.

Copyright. All information furnished within this document, electronic file or design correspondence is the property of Den Hartog industries, Inc. and shall not be used, disclosed to others or copied without the expressed written consent of Den Hartog Industries, Inc.

1248-20

E

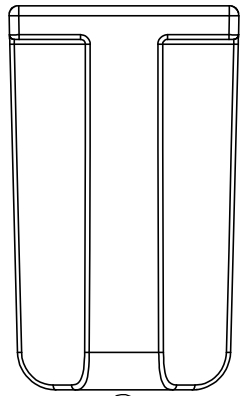
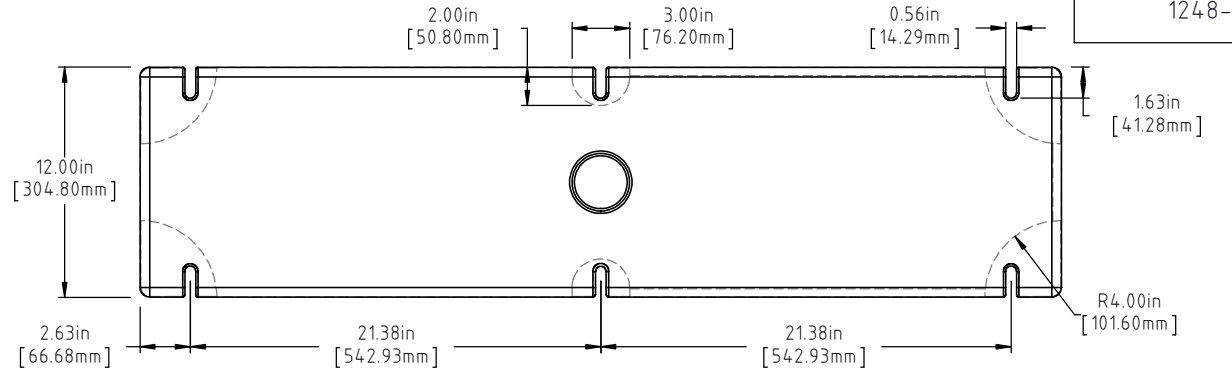

E

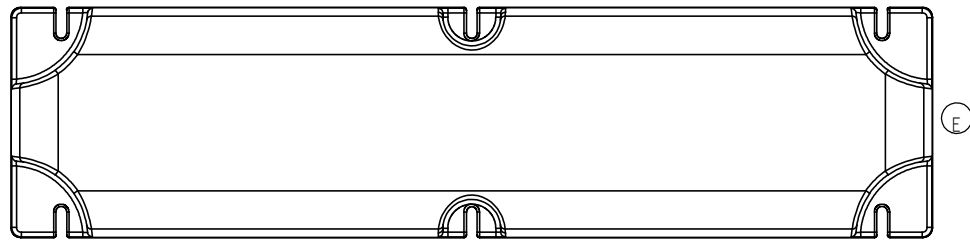
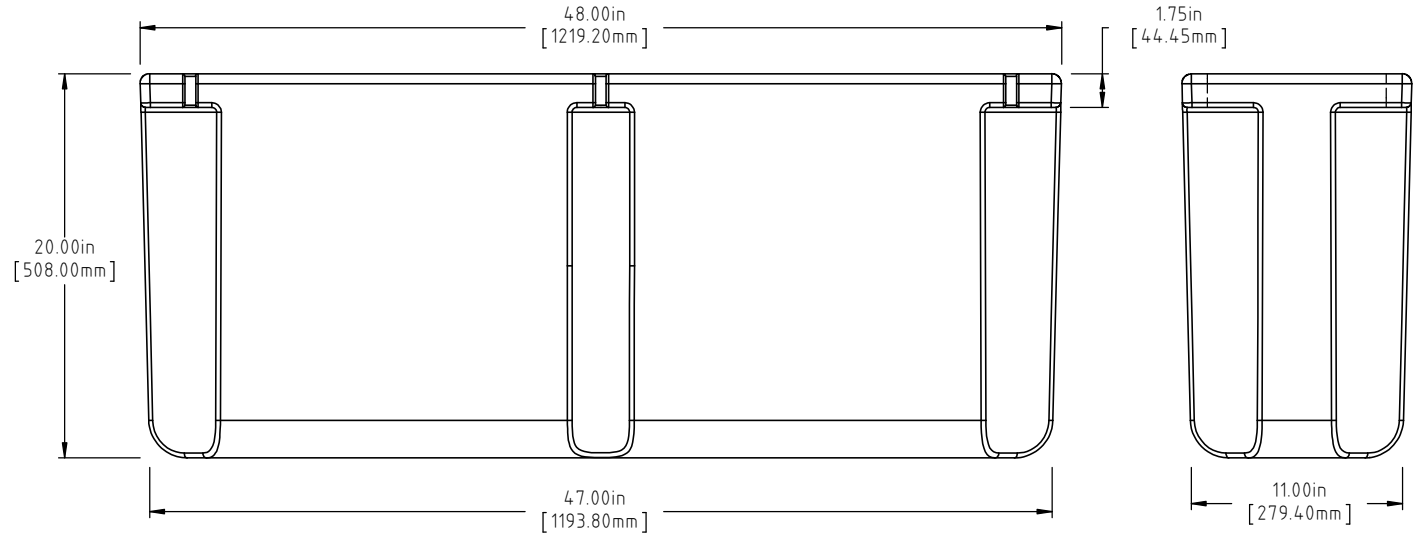

E

ⓓ ⓑ NOTE: BUOYANCY 359 LBS (162.84 KG)

E	BOTTOM AND SIDE VIEWS ADDED TO PRINT	ADH 12/4/14	2971
D	27 LBS WAS 26 LBS, 359 LBS WAS 345 LBS	ADH 6/5/12	2420
C	METRIC UNITS ADDED, DRAWING TEMPLATE UPDATED.	ADH 7/1/08	1685
B	ADD BUOYANCY	GWC 11/29/06	
A	CHANGE WEIGHTS	GWC 11/29/06	
1	CHANGE WEIGHTS	11/17/94	
REV	DESCRIPTION	BY / DATE	CCN

DRAWN / DATE	MATERIAL
DHJ 4/19/94	POLYETHYLENE
APPRD. / DATE	
ADH 11/2/07	



Den Hartog
INDUSTRIES, INC.

Ace Roto-Mold Injection Molding Blow Molding Sowjoy

4010 HOSPERS DRIVE S. BOX 425, HOSPERS, IOWA 51238-0425

ALL DIMENSIONS ARE IN DECIMAL INCHES TOLERANCES UNLESS OTHERWISE SPECIFIED	
POLYETHYLENE	METAL DECIMAL ± .125" FRACTION ± 1/4" ANGLE ± 1°
±1% @ 68°F	

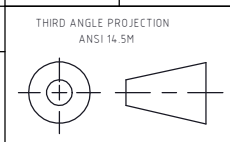

SHOT WEIGHT:	20.00 LBS
SHIPPING WEIGHT:	SEE NOTES
FINISH:	

NOTES: ⓐ ⓓ
AF 20.00 LBS (9.07 KG)
FF 27.00 LBS (12.25 KG)
0.150 (3.81mm) NOM. WALL

DESCRIPTION	12 X 48 X 20 FLOAT
SCALE	N.S.
PART NO.	1248-20